



## Model 3300 Handi-Crimp



### FEATURES

- ◆ Engineered & Designed Specifically for Use with ATCO 3-Barb Style Fittings
- ◆ Portable, Hand Operation
- ◆ Linear or Face Crimp
- ◆ Capable of Crimping Under-Hood Applications
- ◆ Light weight for Easy Handling at Less Than 7 lbs
- ◆ Unit Can be Bench or Wall Mounted
- ◆ Made in U.S.A.

**ATCO Products, Inc**  
601 Interstate 45 South  
Ferris, Texas 75152  
Phone: 972-842-8178  
Fax: 972-544-2164  
[www.atcoproductsinc.com](http://www.atcoproductsinc.com)

# Model 3300 Handi-Crimp

## DISCLAIMER

**WARNING!!** Keep hands clear of the crimp jaws. This machine develops up to 3000 pounds of force and can inflict serious personal injury if not used properly.

**WARNING!!** Always wear eye protection when operating this crimper.

ATCO Products, Inc. shall not be held liable for any injuries incurred when using this equipment. ATCO Products, Inc. shall not be held responsible for any loss of materials or property due to misapplication or misuse of this equipment.

## WARRANTY

ATCO Products, Inc. shall warrant this crimper to the original user against defects in materials or workmanship under normal use for a period of one (1) year after date of delivery. Any part, which is determined to be defective in material or workmanship, will be repaired or replaced at ATCO Products, Inc. option, as the sole remedy.

**EXCEPT AS PROVIDED ABOVE, NO WARRANTY, EXPRESSED OR IMPLIED, INCLUDING WITHOUT LIMITATION WARRANTIES OF MERCHANTABILITY OR FITNESS FOR A PARTICULAR PURPOSE, IS MADE OR AUTHORIZED BY ATCO PRODUCTS, INC.**

## GENERAL

The Model 3300 Crimper is a hand operated hose end-crimping unit specifically designed for use with ATCO “**3-Barb style**” fittings. It is intended for use with SAE J51 A2, two-braid dimension hose using the standard crimp dies provided in the kit. This hose is typically used in R-12 (SAE J51) refrigerant systems.

The longer ATCO ferrule and linear (face) crimp of the Model 3300 insures a superior interface between the hose and the end fittings. In addition, the compact design allows for easy access in confined under-hood areas as well as for complicated end shapes.

**CAUTION:** To insure safe and reliable couplings, use only genuine ATCO “**3-Barb style**” fittings with this crimper.

The crimper can be bench mounted using the flange and short pipe nipple provided or it can be mounted in a bench vise to stabilize the unit. If the unit is used on the vehicle, it will be necessary to use a 12" minimum long pipe nipple extension to counteract the torque while closing the dies. This extension is not provided in the kit.

## OPERATION

**WARNING!!** Always wear eye protection when operating this crimper.

1. Mount the crimper as described previously unless it is necessary to crimp on the vehicle.
2. Select the proper size dies. Check both halves to make sure that they have the same numbers on the side. Each half will be marked identifying the hose size. Example: 5/16" I.D. hose will be marked "6".
3. Open movable tool jaw completely.
4. Loosen the set screws that retain the crimp dies.
5. Insert dies firmly in the tool making sure the flanges of the dies are seated against the jaws. Die identification numbers should be facing the same direction. Tighten set screws.
6. Insert the hose into the ferrule making sure that the hose appears in the small inspection hole on the side or end of the ferrule. Lubricate the barb end of the fitting with refrigerant oil, then install into hose, aligning the hose end with the stop on the fitting. A hose pusher (ATCO part number 3535 is recommended) may be necessary in order to achieve this.

**CAUTION:** If the hose does not appear in the inspection hole, a poor crimp may result.

**WARNING!!** Keep hands clear of the crimp jaws. This machine develops up to 3000 pounds of force and can inflict serious personal injury if not used properly.

7. Place the assembly into the crimper and center the ferrule in the crimp dies. Tighten crimper until dies are completely closed.

**CAUTION:** Torque should not exceed 65 ft/lbs. Use of an impact wrench will void the warranty on this crimper.

8. To remove the crimped assembly, loosen the crimper drive bolt until assembly can be removed freely.

9. Inspect the first crimp to make sure that the correct dies were used, the crimp location is correct, the crimp is uniform and there is no internal deformation of the fitting.

**NOTE:** Some hose materials trap air in the hose layers during manufacture. When leak testing a newly pressurized hose using soap bubbles or water submersion, the air in the hose will bleed out at the fitting and hose interface indicating a false leaking condition. Leave the hose pressurized for one hour and re-test. The residual air should completely bleed out and no leak will be visible.

## CRIMPER MAINTENANCE

1. Clean and lubricate the drive bolt and slide.

## TROUBLESHOOTING

PROBLEM	CAUSE	ACTION
Crimp location too close to closed end of ferrule	Ferrule not centered on crimp dies	Center Ferrule
Crimp location too close to hose	Ferrule not centered on crimp dies	Center Ferrule
Crimped fitting leaks when tested with soap bubbles	Air trapped in the hose during manufacture  Insufficient crimp  Fitting is defective	Recheck after system has been charged for one hour - air will bleed out of the hose  Make sure crimper is fully closed  Replace fitting/re-crimp
Crimped fitting leaks when tested with electronic leak detector	Insufficient crimp  Fitting defective	Make sure crimper is fully closed  Replace fitting/re-crimp
Retaining Pin damaged	Excessive reversing of drive bolt	Replace retaining pin
Crimper Body Broken	Excessive torque applied to drive bolt	Replace crimper body

# Model 3300 Replacement Parts

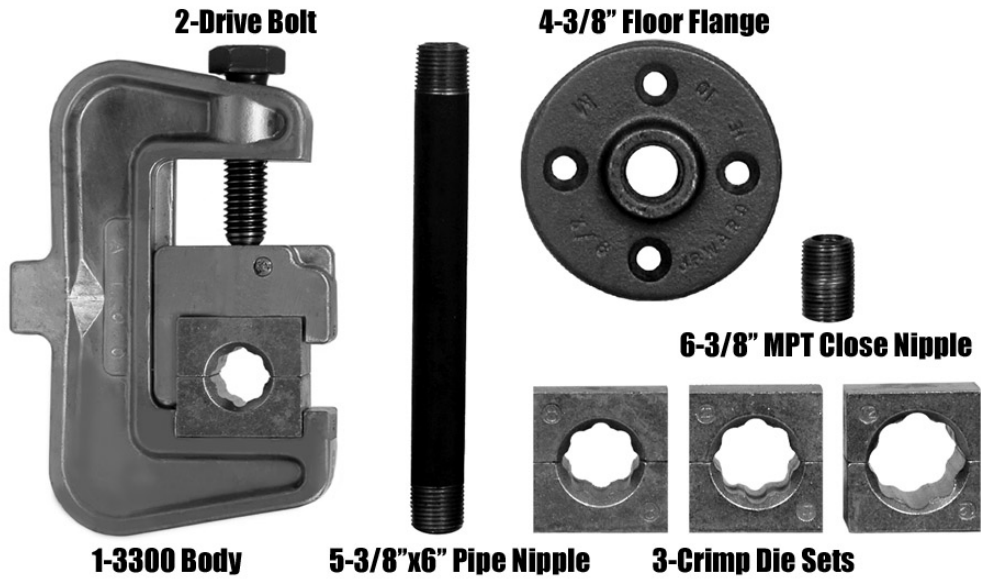

Item	Part Number	Description	Quantity
1	3330	3300 Crimper (Body Only)	1 Each
	3340	3300 Crimper (No Dies)	1 Each
2	3304	Drive Bolt	1 Each
3	3306	No. 6 Crimp Die Set	1 Set
	3308	No. 8 Crimp Die Set	1 Set
	3310	No.10 Crimp Die Set	1 Set
	3312	No.12 Crimp Die Set	1 Set
4	3321	3/8" Floor Flange	1 Each
5	3320	3/8" x 6" Pipe Nipple	1 Each
6	3322	3/8" MPT Close Nipple	1 Each